

# XA(T,H,V)S 146-186 Dd

## Portable compressor



### Standard Scope of Supply

The Atlas Copco **XA(T,H,V)S 146-186 Dd** is a single-stage oil-injected asymmetrical rotary screw type air compressor, powered by a liquid-cooled, four cylinder turbo-charged, inter-cooled Deutz COM III/Tier 3 (COM II/Tier 2) compliant diesel engine.

The unit consists of one high efficient compressor element, diesel engine, cooling, air/oil separation and control systems - all enclosed within either un-silenced (XA) or sound dampened (XAS) strong steel canopy.

A broad range of undercarriage types and standard factory installed options are available.

Special attention has been given to the overall product quality, user friendliness, ease of serviceability, and economical operation to ensure best in class cost of ownership.

### Available Models

XAHS 146 Dd	single stage - 12 bar – Com3 compliant Deutz engine
XATS 156 Dd	single stage - 10.5 bar - Com3 compliant Deutz engine
XAVS 166 Dd	single stage - 14 bar - Com3 compliant Deutz engine
XAHS 186 Dd	single stage - 12 bar - Com3 compliant Deutz engine
XA(S) 186 Dd	single stage - 7 bar – Com2 compliant Deutz engine
XAS 186 Dd	single stage - 7 bar - Com3 compliant Deutz engine

### Features

- Full compliance with 2000/14/EC, the latest European Outdoor Noise Directive
- Guaranteed free air delivery in accordance with ISO 1217 ed. 3 1996 annex D
- Zincor treated canopies with powder coat paint finish
- Modular design
- Few moving parts
- Controls grouped on one panel
- Engine speed adapts to air dem
- Compliant with exhaust emission standards 97/68/EC step II and step III (Europe) & EPA Tier II and Tier III (USA)
- Long service intervals

### Benefits

- Units can be operated in the vicinity of hospitals, schools, residential areas and even at night and comply with international legislation
- Measured at the outlet valves, you get the amount of air you paid for
- Improved resistance to corrosion and higher resale value
- Easy accessibility for service and maintenance, Toolbox as standard, Fewer parts
- Reliability second to none and long working life
- Easy to monitor and control
- Economical power and fuel consumption, Stable air flow
- Meets the strictest environmental requirements
- Low operating costs

## Technical Data

		XAHS 146	XATS 156	XAVS 166
		Dd C3	Dd C3	Dd C3
<b>Compressor</b>				
Normal effective working pressure	bar	12	10.5	14
Actual free air delivery <sup>1</sup>	l/s	151	161	158
Max. sound power level (Lw) <sup>2</sup>	dB(A)	99	99	99
Max. sound pressure level at 7 m (Lp)	dB(A)	71	71	71
Oil Capacity	l	23.5	23.5	23.5
Max. ambient temperature	°C	50	50	45
Air Compressor outlets		1 x 1 1/2" / 3 x 3/4"	1 x 1 1/2" / 3 x 3/4"	1 x 1 1/2" / 3 x 3/4"
Maximum altitude	m	5000	5000	5000
Minimum starting temperature	°C	-10	-10	-10
<b>Engine</b>				
Caterpillar		TCD2012L04	TCD2012L04	TCD2013L04
Number of cylinders		4	4	4
Output at rated speed	kW	83	83	104
Swept volume	l	4	4	4.76
Engine speed (nominal)	r/min	2300	2300	2200
Engine speed (unloaded)	r/min	1700	1700	1700
Capacity oil system	l	8.5	8.5	10.5
Capacity of fuel tank	l	175	175	175
Fuel consumption at 100% load	kg/h	18.1	18	21.2
		XAHS 186	XA(S) 186	XAS 186
		Dd C3	Dd C2	Dd C3
<b>Compressor</b>				
Normal effective working pressure	bar	12	7	7
Actual free air delivery <sup>1</sup>	l/s	173	185	185
Actual free air delivery with aftercooler <sup>1</sup>	l/s	169	-	-
Max. sound power level (Lw) <sup>2</sup>	dB(A)	99	102	99
Max. sound pressure level at 7m (Lp)	dB(A)	71	74	71
Oil Capacity	l	23.5	24	23.5
Max. ambient temperature	°C	45	50	50
Max. ambient temperature with aftercooler	°C	40	-	-
Air Compressor outlets		1 x 1 1/2" / 3 x 3/4"	1 x 1 1/2" / 3 x 3/4"	1 x 1 1/2" / 3 x 3/4"
Maximum altitude	m	5000	5000	5000
Minimum starting temperature	°C	-10	-10	-10
<b>Engine</b>				
Deutz		TCD2013L04	BF4M2012C	TCD2012L04
Number of cylinders		4	4	4
Output at rated speed	kW	104	80	83
Swept volume	l	4.76	3	4
Engine speed (nominal)	r/min	2100	2500	2300
Engine speed (unloaded)	r/min	1700	1700	1700
Capacity oil system	l	10.5	19	8.5
Capacity of fuel tank	l	175	175	175
Fuel consumption at 100% load	kg/h	21	17.8	17.4

<sup>1</sup> according to ISO 1217 ed.3 1996 annex D

<sup>2</sup> according to 2000/14/EC, 84/533/EEC and 85/406/EEC limits

## Dimensions

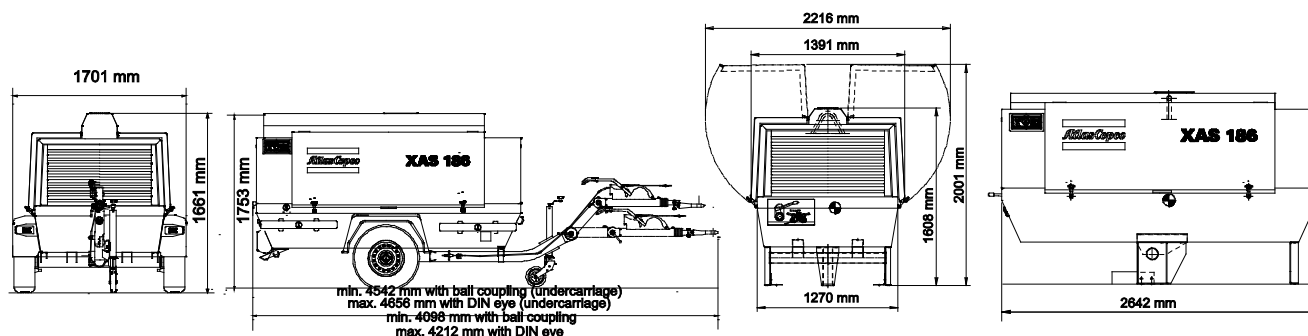

## Weight (Ready-to-operate)

		XAHS 146	XATS 156	XAVS 166
		Dd C3	Dd C3	Dd C3
Fixed towbar – no brakes	kg	1705	1705	-
Fixed / adjustable towbar - brakes	kg	1800 / 1825	1800 / 1825	1883
		XAHS 186	XA(S) 186	XAS 186
		Dd C3	Dd C2	Dd C3
Fixed towbar – no brakes	kg	-	1705	1705
Fixed / adjustable towbar - brakes	kg	-	1800 / 1825	1800 / 1825

## Options

- Additional pressure gauge (standard on XAHS 186)
- Inlet filter safety cartridge (standard on XAHS 186)
- Cold start (-20°C)

## Vessel type

- EC
- ASME

## Tow bar

- Adjustable with brakes
- Fixed with brakes
- Fixed without brakes

## Towing eyes

- Atlas Copco
- DIN
- Skid
- Ball coupling
- Italian
- NATO

## Tow bar support

---

- Leg
- Jockey wheel
- Wheel chocks

## Refinery equipment

---

- Spark arrestor
- Inlet shutdown valve

## Customer colour

---

- Single
- Double
- Triple

## Principle Data

---

### Compressor Element

---

The quality of a compressor can be measured through the reliability, efficiency and durability of the compressor element used. Through decades of expertise in the design of compressor elements, the result is the production of most efficient and reliable compressors on the market. When the screw element is efficient- durability excels, maintenance intervals increase and fuel consumption goes down.

### Air/Oil Separator

---

Air and oil separation is achieved through a centrifugal oil separator combined with a filter element. Separators are available in CE and ASME, approved versions and are stamped accordingly. Designed for a higher maximum working pressure, the separator is equipped with a sealed high pressure safety relief valve, minimum pressure nozzle, automatic blow-down valve, and pressure regulator.

The compressor is delivered as standard with mineral based compressor oil.

### Cooling System

---

The cooling system consists of an integrated side-by-side aluminium oil cooler with axial fan to ensure optimum cooling. The cooling system is suitably designed for continuous operation in ambient conditions up to +50°C, with all canopy doors closed.

The compressor is delivered as standard with radiator coolant PARCOOL.

### Compressor Regulating System

---

The compressor regulating system consists of air filter, air receiver/oil separator, compressor element, unloader assembly with unloader valve, blow down valve and loading valve.

Economical power consumption is assured by the fully automatic step-less speed regulator that adapts engine speed to air demand.

### Discharge Outlets

---

Compressed air is available from 1 x 1 1/2" and 3 x 3/4" outlet valves.

## Engine

---

### Deutz BF4M2012C

---

COM II/Tier 2 compliant four -cylinder, liquid-cooled diesel engine provides ample power to operate the compressor continuously at full-load.

Engine output at rated speed, in accordance to SAE standard is 88kW at 2300 rpm.

The engine has the capability to start the compressor to -10°C without the addition of a cold start aid. Cold start options are available for up to -25°C.

The fuel tank is sufficiently sized to operate the unit for minimum of 8 hours at full-load condition.

## Deutz TCD2012-L04

COM III/Tier 3 compliant four -cylinder, liquid-cooled diesel engine provides ample power to operate the compressor continuously at full-load.

Engine output at rated speed, in accordance to SAE standard is 83kW at 2300 rpm.

The engine has the capability to start the compressor to -10°C without the addition of a cold start aid. Cold start options are available for up to -25°C.

The fuel tank is sufficiently sized to operate the unit for minimum of 8 hours at full-load condition.

## Deutz TCD2013-L04

COM III/Tier 3 compliant four -cylinder, liquid-cooled diesel engine provides ample power to operate the compressor continuously at full-load.

Engine output at rated speed, in accordance to SAE standard is 104kW at 2200 rpm.

The engine has the capability to start the compressor to -10°C without the addition of a cold start aid. Cold start options are available for up to -25°C.

The fuel tank is sufficiently sized to operate the unit for minimum of 8 hours at full-load condition.

## Electrical System

The **XA(T,H,V)S 146-186 Dd** is equipped with a 12 Volt negative ground electrical starting system.

## Instrumentation

The instrument control panel is located on the back, curb side of the compressor canopy, with a protective metal cover for safety and protection.

Standard instrument package includes a running hourmeter, operating pressure gauge, load button, three position start/stop switch, and LED diagnostic warning & shutdown lamps.

Starting is achieved with a three position switch for ease of operation.



## Safety Devices

The compressor is standard equipped with safety devices for the compressor and the engine. The unit will be completely turned off should:

- Engine oil temperature rise too high
- Engine oil pressure drop too low
- Outlet temperature of the compressed air go outside a specified range
- Low fuel level

The starter motor is also protected against overloading from operating for an excessive period or when the engine is running.

## Bodywork

The compressor is delivered as standard with a zincor coated steel canopy with powder coat paint finish providing excellent corrosion protection. The canopy is available in either un-silenced or sound attenuated versions to meet the most current legal noise requirements. Wide doors provide complete service access to all components.

The standard colour combination is Atlas Copco Yellow and RAL 7015 grey, however, other colour combinations are also available on demand.

## Undercarriage

The **XA(T,H,V)S 146-186 Dd** compressor is available with numerous undercarriage alternatives, providing utmost flexibility in installation or towing requirements.

- Support mounted version less undercarriage
- Skid mounted
- 2-wheel style fixed height undercarriage with or without brakes
- 2-wheel style adjustable height undercarriage with or without brakes

## Manufacturing & Environmental Standards

---

The **XA(T,H,V)S 146-186 Dd** is manufactured following stringent ISO 9001 regulations, and by a fully implemented Environmental Management System fulfilling ISO 14001 requirements.

Attention has been given to ensure minimum negative impact to the environment.

The **XA(T,H,V)S 146-186 Dd** meets COM II / Tier 2 Exhaust and noise emission directives.

## Supplied Documentation

---

The unit is delivered with certificates regarding:

- Test certificate for air delivery pressure and capacity, acc. ISO 1217
- Certificate for air/oil separator vessel and safety valve approval (CE/ASME)
- Declaration of conformity (for CE variants only)
- Operating and instruction manual
- Spare parts manual

## Warranty Coverage

---

For our standard warranty conditions and options to extend, please check your local Atlas Copco representative.